

COMBOTRAB

Combination Lightning Protection and Transient Voltage Surge Suppression TVSS

Installation Instructions 1163D
PN 5651462

December 2002

Models

120/240 V AC, Split, Single-phase

Enclosures: 5602856, 5603167, 5603416, 5603417 & Kit: 5603030

208/120 V AC WYE, 3-phase

Enclosures: 5602745, 5602733, 5602202, 5602747 & Kit: 5603415

240 V AC, 3-phase, High Delta

Enclosures: 5602745, 5602733, 5603463, 5603464 & Kit: 5603415

480/277 V AC, WYE, 3-phase

Enclosures: 5602744, 5602732, 5602201, 5602746 & Kit: 5602794

480 V AC, Ungrounded Delta

Enclosures: 5603419, 5603418, 5603420, 5603421 & Kit: 5603422

1. Product Description

COMBOTRAB protection panels are self-contained systems for protecting main power from the damaging effects of a direct lightning strike. Figure 1 shows the basic components of the COMBOTRAB system.

Systems are installed on the secondary side (low voltage side) of the distribution transformer feeding the service entrance of a facility. See Figure 2. As a UL-listed TVSS device, the COMBOTRAB system must be connected to the load side of the main service disconnect, or to the load side of a protected circuit's disconnecting means. Because the unit's primary function is as a lightning arrester, it is recommended that it al-

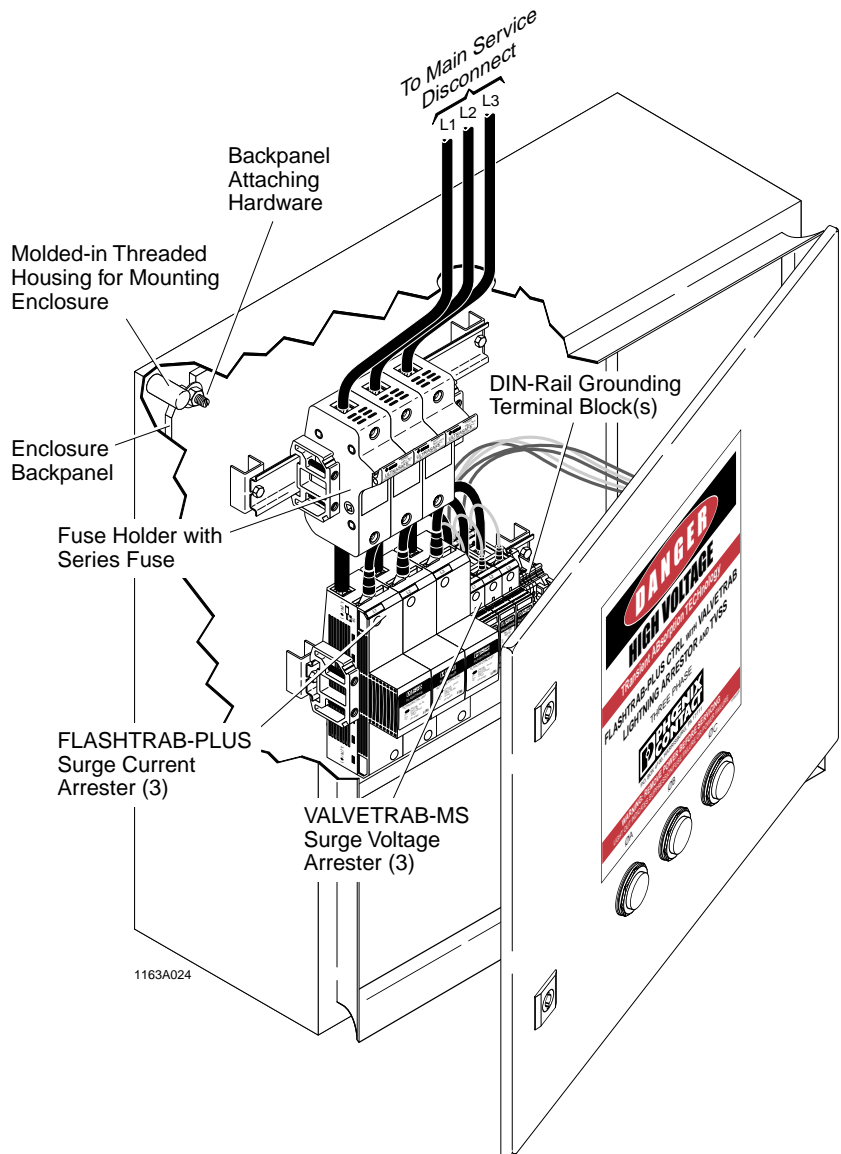

Figure 1. Features of the COMBOTRAB TVSS Lightning Protection System

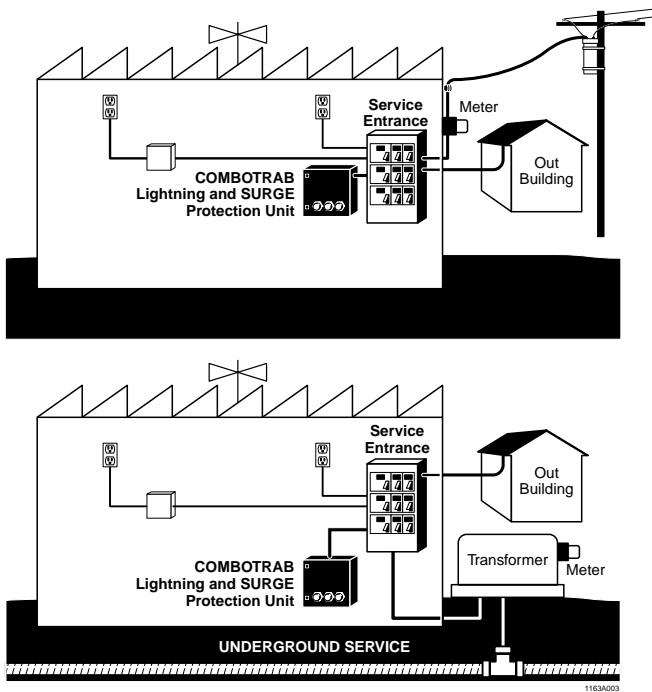

Figure 2. Locating the COMBOTRAB Lightning Protection System

ways be installed at the main service entrance to a facility or electrical installation. For proper operation it is important that the installation point will be where a neutral to Ground bond exists as required by NEC for service entrance power.

The lightning arresting components of the COMBOTRAB are the FLASHTRAB – PLUS – CTRL. These lightning arresters utilize a self-extinguishing spark-gap technology to effectively prevent the high-voltage and damaging currents associated with lightning strikes from entering your facility and causing damage to your electrical equipment. COMBOTRAB systems include Phoenix Contact VALVETRABs for transient voltage surge suppression (TVSS). COMBOTRAB systems also contain replaceable surge-rated fuses (200 kA IR). Diagnostic light indicators are also available on some models.

For maximum system performance and protection, coordinated surge protection should be installed throughout an installation. This includes point of use protection at critical loads, protection of phone lines, industrial data and I/O signals, networking cables, etc.

2. General Installation Guidelines

Read and follow all guidelines in these procedures before installing your COMBOTRAB system. The COMBOTRAB protection panel should be installed by an authorized electrician. Local electrical codes, regulations and guidelines must be observed.

WARNING

To prevent personal injury due to electrical shock, always disconnect service power to the COMBOTRAB protection panel prior to installing or repairing the panel. Mount the protection panel as close to the main service switchboard as possible to minimize wiring distance.

Due to high-voltage arcing that may occur in this device, DO NOT install the panel in locations where combustible materials are present in the atmosphere.

When wiring the panel, always verify the neutral-to-ground bond.

CAUTION

Do NOT exceed the maximum "Line-to-Ground" voltage listed on the label inside the enclosure door or the label supplied with the kit package.

The COMBOTRAB protection panel should be installed after the main service disconnect. Refer to Figure 2. This is a parallel installation between each phase and earth ground. The fusing in series with each FLASHTRAB surge arrester is intended to disconnect only in the unlikely event of a short circuit in the FLASHTRAB or VALVETRAB modules.

Note

The appropriate cable entry should be determined and cut before mounting the COMBOTRAB to your wall or mounting strut. Figure 9 shows possible conduit locations. Wiring should always be as straight as possible, avoid sharp bends.

3. System Wiring

The COMBOTRAB can be installed directly to the main power bus or to an available circuit breaker. Many customers choose to install the panel to a circuit breaker for both convenience and to function as a disconnect. See Figures 3 through 6 for wiring diagrams.

Follow NEC and applicable local codes when connecting the COMBOTRAB directly to the bus bar. If connection to a circuit breaker, see Table 1 for the size of wire applicable to the breaker being used. Figure 7 provides the strip-length requirement of a wire.

Table 1. Proper Breaker Size

Connecting Wire Size (AWG)	Breaker Rating (Amperes)
8	≤ 60
6	≤ 100—150
4	≤ 160
2	≤ 200
1/0	≤ 250

1163A034

120/240 V AC Split, Single-Phase Systems

Enclosures: 5602856, 5603167, 5603416, 5603417
Kit: 5603030

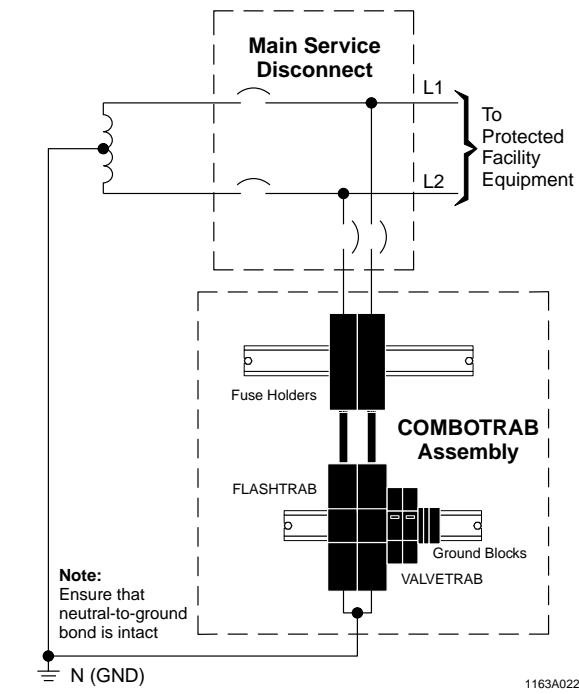

1163A022

Figure 3. 120/240 V ac, Split, Single-phase, Wiring Diagram

208/120 V AC WYE Systems

Enclosures: 5602745, 5602733, 5602202, 5602747
Kit: 5603415

480/277 V AC WYE Systems

Enclosures: 5602744, 5602732, 5602201, 5602746
Kit: 5602794

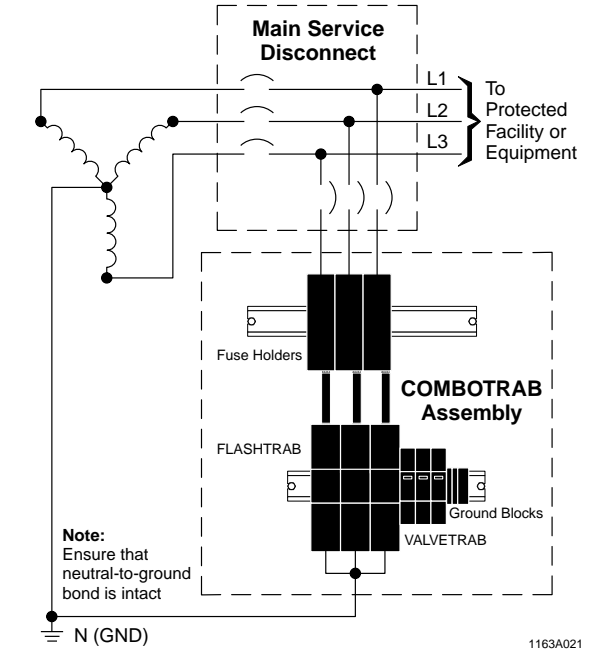

1163A021

Figure 4. 208/120 & 480/277 V ac, WYE, 3-phase, Wiring Diagram

240 V AC High-leg DELTA Systems

Enclosures: 5602745, 5602733, 5603463, 5603464
Kit: 5603415

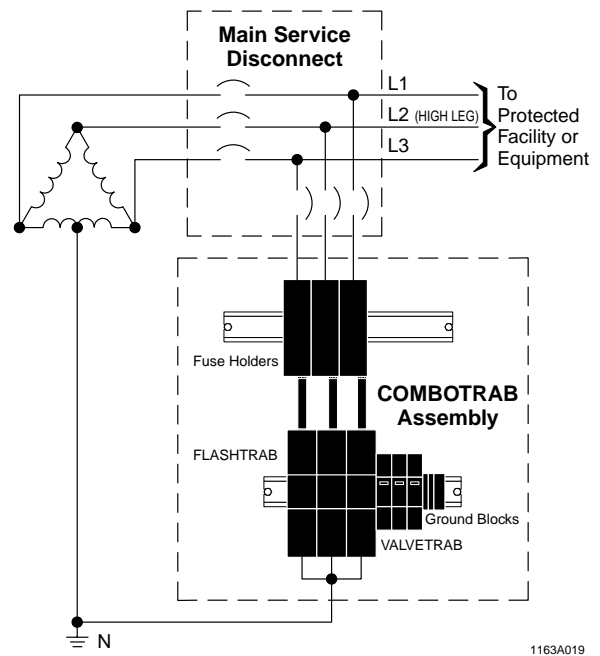

1163A019

Figure 5. 240 V ac, High-leg Delta, 3-phase, Wiring Diagram

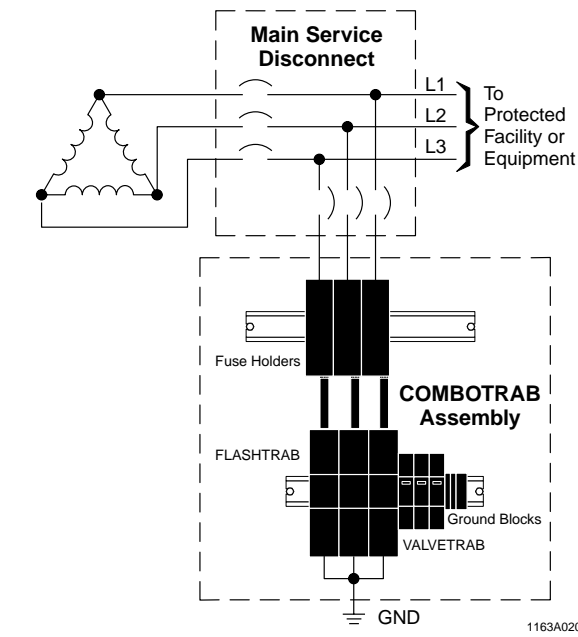

Figure 6. 480 V ac, Ungrounded Delta, 3-phase, Wiring Diagram



Figure 7. Phase Conductor and Ground Conductor Strip-length Requirement

4. COMBOTRAB Fusing

The COMBOTRAB protection panel is protected by a 200 kA (8/20 ms) fuse. See Figure 8. This fuse makes the panel suitable for use on circuits capable of delivering not more than 50,000 rms symmetrical amperes, 385 Volts maximum.

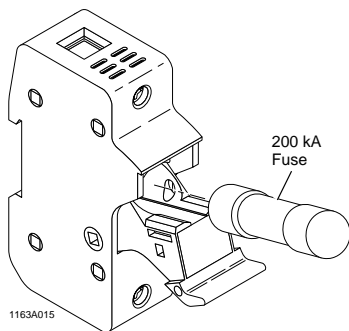
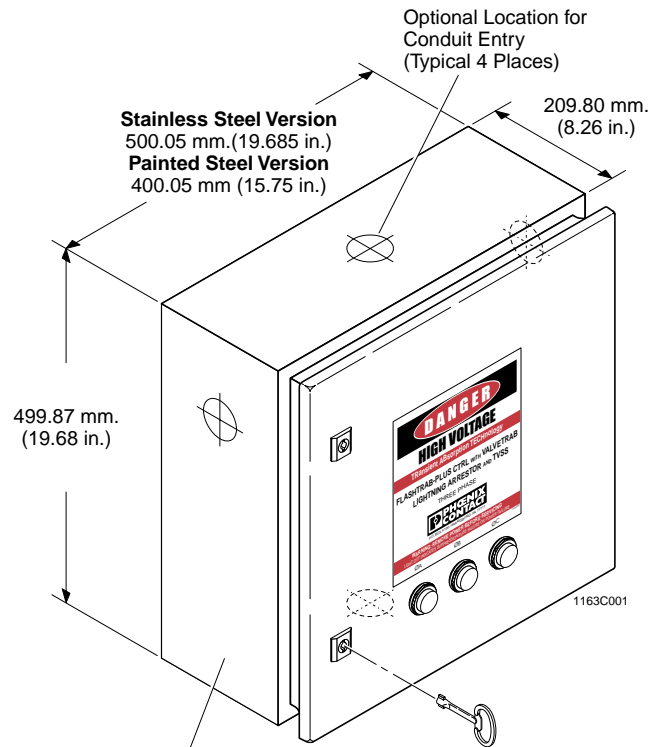

Figure 8. COMBOTRAB Fuse Holder & Fuse

5. COMBOTRAB Enclosure Dimensions

COMBOTRAB enclosure systems and kits are intended to be wall mounted. Enclosure dimensions for both the stainless steel and painted steel versions are shown in Figure 9. For maximum performance, plan your installation so that connecting cable length is kept to a minimum.



Enclosure Protection: Meets or Exceeds IP-67 or NEMA 4 (for painted steel version); IP-67 or NEMA 4X (for stainless steel version)

Figure 9. Enclosure Dimensions

6. COMBOTRAB Kit Installation

IMPORTANT

The COMBOTRAB Kit is a UL Recognized assembly. For UL Listing, additional evaluation in the final installation will be required.

COMBOTRAB protection is also available as a DIN-rail mounting kit for installation with user-supplied panels. Figure 10 shows hole mounting dimensions and locations.

Each kit includes two sets of standoffs. One set of standoffs is required for each DIN-rail. Figure 11 shows drill size and parts assembly for each standoff.



WARNING

The standoffs facilitate venting of the FLASHTRAB and should be used in all installations.

Note

If the COMBOTRAB enclosure is equipped with light indicators, lights will come ON when power is applied to the unit.

- Turn ON power to the COMBOTRAB unit.

13. Troubleshooting

a. COMBOTRAB Units with Light Indicators

If any indicator light on the COMBOTRAB front panel is not ON, follow the procedure described in the following paragraphs.

- Verify that power to the COMBOTRAB unit is ON. If not ON, turn power ON and check lights.



WARNING

To prevent personal injury due to electrical shock, always disconnect service power to the COMBOTRAB protection panel prior to installing or repairing the panel.

- Turn OFF power to the COMBOTRAB unit.

Condition 1 - Defective MOV Plug

- Open the door of the COMBOTRAB enclosure and check for defective VALVETRAB MOV plug(s). The word "DEFECT" will appear in the window at the top of the plug. See Figure 20. If the word "DEFECT" appears in the window, proceed to Step 4. If the word "DEFECT" does not appear in the window, proceed to Step 6.
- Replace defective VALVETRAB MOV plug(s) as described in Paragraph 10.
- Close the COMBOTRAB enclosure door. Then turn ON power to the COMBOTRAB unit. The Indicator lamp should now be lit.

Condition 2 - Defective Fuse



WARNING

To prevent personal injury due to electrical shock, always disconnect service power to the COMBOTRAB protection panel prior to installing or repairing the panel.

- If all VALVETRAB MOV plugs are NOT defective, open each ULTRASAFE fuse holder in the COMBOTRAB enclosure and verify fuse operation by performing a continuity check.

- If fuse(s) is found to be defective, proceed to Step 8. If fuse(s) is OK, proceed to step 9.
- Replace fuse(s) as described in Paragraph 12. Then turn ON power to the COMBOTRAB unit. The Indicator lamp should now be lit.

Condition 3 - Defective Bulb



WARNING

To prevent personal injury due to electrical shock, always disconnect service power to the COMBOTRAB protection panel prior to installing or repairing the panel.

- If both fuses and VALVETRAB MOV plugs are OK, replace the light bulb(s) in any lamp assembly where the bulb is not lit. Refer to Paragraph 11 for bulb replacement.
- Turn ON power to the COMBOTRAB unit. Indicator lamp(s) should now be lit.

14. Technical Data (See Table 2)

Table 2. Typical COMBOTRAB Specifications

	480/277 V AC WYE	208/120 V AC WYE 240 V AC DELTA 120/240 HL DELTA	120/240 V AC Split, Single-Phase
Maximum continuous operating current	350 V ac (L-N and L-GND)	275 V ac (L-N and L-GND)	275 V ac (L-N and L-GND)
Protection mode (installed on main service Entrance with N-GND bond)	L-L L-N L-GND	L-L L-N L-GND	L-L L-N L-GND
UL 1449, 2nd edition, SVR (500 A, 6 kV combination wave)	1.2 kV	850 V	850 V
ANSI/IEEE C62.41, Category C3 combination wave (10 kA, 20 kV)	<1.5 kV	<900 V	<900 V
50 kA 10x20 μS	<1.5 kV	<900 V	<900 V
50 kA (10x350 μS)	<1.5 kV	<900 V	<900 V
Surge current capacity (10x350 μS)	50,000 amps*	50,000 amps*	50,000 amps*
Follow current interrupting capacity	>50,000 amps**	>50,000 amps**	>50,000 amps**
Repetitive surge event 20 kV/10 kA (ANSI/IEEE C62.41 category C3 surge event)	>7,000 impulses	>7,000 impulses	>7,000 impulses
Repetitive surge event 50 kA 10x350 IEC 61312	>7,000 impulses	>7,000 impulses	>7,000 impulses

* 50,000 amps 10x350 μS similar to charge of 1 million amps 8x20 μS.

** Evaluated by UL Duty Cycle Testing. FLASHTRAB interrupted 50,000 amps without damage of the FLASHTRAB or series fusing.

Note: Repetitive Surge Current Testing was conducted with 20 kV/10 kA IEEE Category C3 combination wave at 1-minute intervals, <5 kA available follow current. Testing stopped with no failure characteristics at 7,000 impulses.

1163A038

15. Illustrated Parts List

Figures 30 and 31 provide exploded views of a typical COMBOTRAB system with and without light indicators. Tables 3 is an itemized list of parts for Figure 30 and Table 4 is an itemized list of parts for Figure 31.